

104-AIO12-8
104-AI12-8
104-AO12-4

12-Bit PC/104 MULTIFUNCTION ANALOG I/O

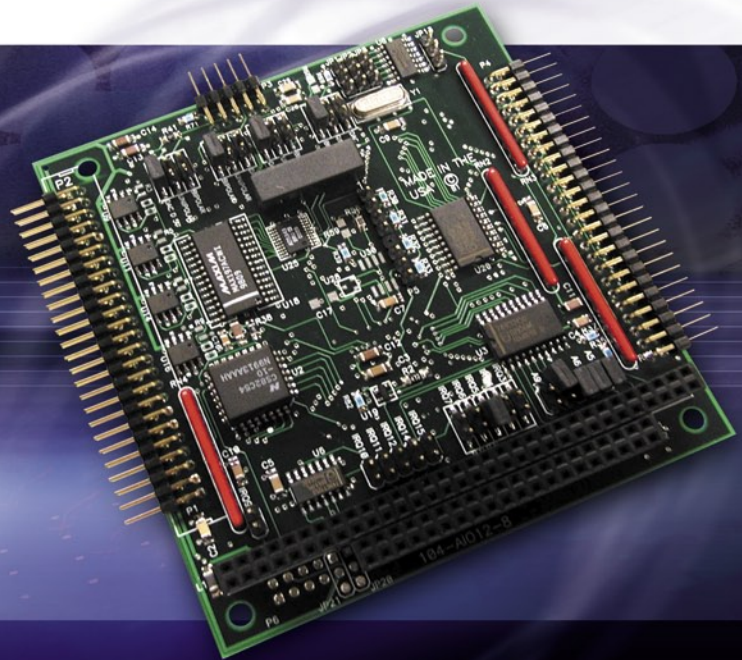
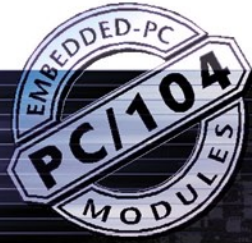

KEY FEATURES:

- Eight single-ended or true differential inputs
- Programmable input ranges of: 0-5V, 0-10V, $\pm 5V$, $\pm 10V$
- 100KHz sampling rate
- On-board pacer clock and counter timers
- Four double-buffered analog outputs
- Jumper selectable output ranges of: 0-5V, 0-10V, $\pm 5V$, $\pm 10V$
- 24 digital I/O lines, type 82C55 with change of state detect on port C, buffers on ports A & B
- Flexible configurations to suit your needs

FACTORY OPTIONS:

- 4-20mA inputs with offset
- Channel by channel pre-amplifier gains of 1-100
- +5VDC only operation
- 0 to +70°C and -40 to +85°C versions available
- Inputs or outputs only versions available

The 104-AIO12-8 is a low-cost 12-channel analog multifunction I/O board which features an excellent price/performance value for PC/104-based data acquisition. The inherent "selectability" of the card's onboard features allows the depopulation of unnecessary functionality. This keeps costs down by allowing the user to more precisely specify the board to the application's unique requirements. The 104-AI12-8 has no outputs while the 104-AO12-4 has no inputs.

The 104-AIO12-8 provides eight single-ended or eight true differential analog input channels with 12-bit resolution. 200V common-mode rejection, high input impedance (2MegOhms, typical) and factory pre-settable gain to accommodate low-level sensor inputs are also included. Analog inputs are software programmable for 0-5V, 0-10V, $\pm 5V$ and $\pm 10V$, and optionally factory configurable for 4-20mA. The same ranges are jumper-selected for the four channels of 12-bit analog output. 24 parallel lines of digital I/O, eight of which also provide change-of-state detection, are also provided for a complete, low cost, multifunction data acquisition solution.

SOFTWARE

The 104-AIO12-8 Series are supported for use in most operating systems and include a free DOS, Linux and Windows 95/98/Me/NT/ 2000/XP/2003 compatible software package. This includes sample programs and source code in "C" and Pascal for DOS, and Visual Basic, Delphi, C++ Builder, and Visual C++ for Windows. Also included is a graphical setup program in Windows. Linux support includes installation files and basic samples for programming from any user level via an open source kernel driver.



ACCES I/O Products, Inc. 10623 Roselle Street San Diego, CA 92121
Tel: (858) 550-9559 (800) 326-1649 Fax: (858) 550-7322
Email: contactus@accessio.com Website: www.accessio.com

Block Diagram & Pin Configuration

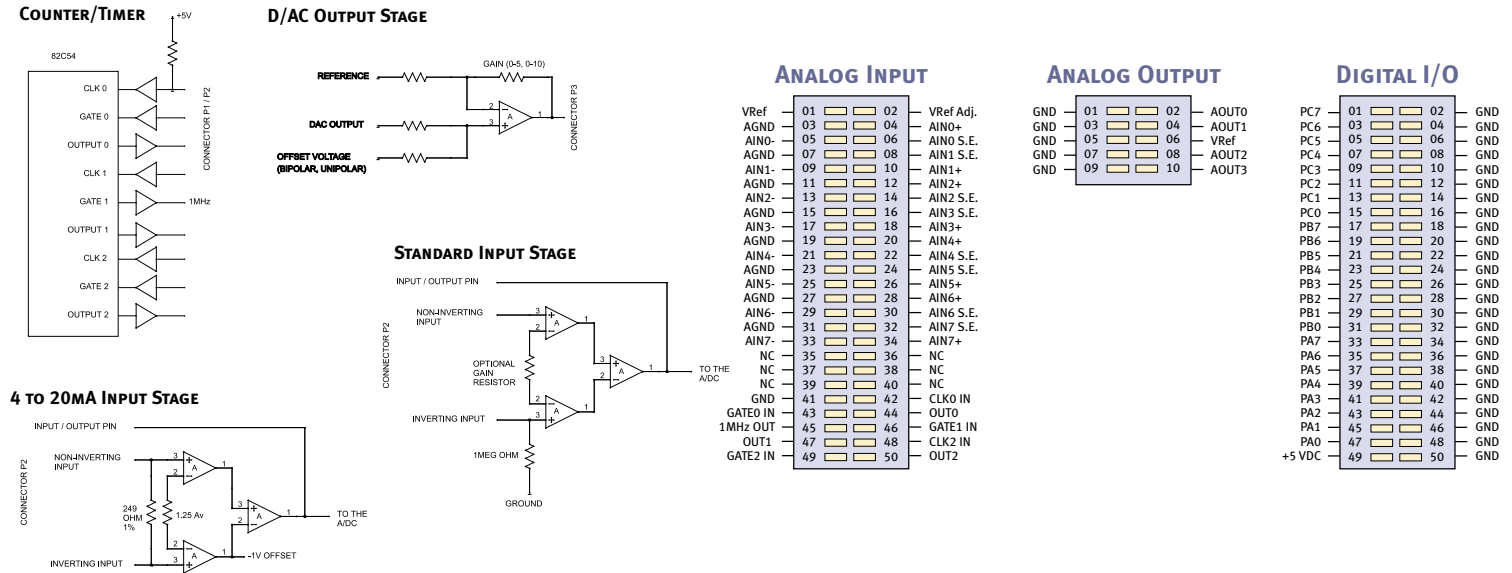

Specifications

A/D

Number of inputs	8 single-ended or 8 true differential
Resolution	12-bit
Bipolar ranges	±5V, ±10V (4-20mA factory option)
Unipolar ranges	0-5V, 0-10V
Sampling rate	100 KHz
Type	Successive Approximation
Nonlinearity	±1 LSB max, monotonic
Common mode voltage	±200V
Trigger source	Software selectable: programmable timer, program command

Digital I/O

Number of I/O	24, pulled up to +5V
Type	82C55A
Input voltage	Logic low: -0.3V min, 0.8V max; Logic high: 2.2V min, 5.8V max
Input current	±1µA max
Outputs	Logic low: 0.0V min, 0.4V max; Logic high: 3.7V min, 5.0V max
Output current (Ports A & B)	Logic low: 64mA max sink; Logic high: 32mA max source
Output current (Ports C)	Logic low: 2.5mA max sink; Logic high: 2.5mA max source
Change of state	Port C enabled with change of state detection

D/A

Number of outputs	4
Resolution	12-bit resolution
Bipolar ranges	±5V, ±10V
Unipolar ranges	0-5V, 0-10V
Conversion rate	100 KHz
Relative accuracy	±2 LSB
Output current	3mA per channel

Counter/Timer

Type	82C54
Counters/timers	3 x 16-bit
Clock Frequency	1MHz
Software support	Event counter, frequency output, frequency pulse and measurement

General

Power required (Using optional DC/DC converter)	+5V @ 240mA typ
Power required (Using ±12V and +5V)	+12VDC: 30mA typical; -12VDC: 30mA typical; +5VDC: 40mA typical
Interrupt requests	IRQs 3-7, 9-12, 14, 15
Operating Temperature	0 to +70°C, optional -40 to +85°C
Storage Temperature	-50 to +120°C
Humidity	5% to 95% RH, non-condensing

Ordering Guide

104-AI012-8	12-bit, 8-channel A/D, 4 analog outputs and 24 digital I/O
104-AI12-8	12-bit, 8-channel A/D and 24 digital I/O (no outputs)
104-AO12-4	12-bit, 4 analog outputs and 24 digital I/O (no inputs)



ACCES I/O Products, Inc. 10623 Roselle Street San Diego, CA 92121
Tel: (858) 550-9559 (800) 326-1649 Fax: (858) 550-7322
Email: contactus@accessio.com Website: www.accessio.com